

Heraeus



CIR[®]
Carbon Infrared Emitter
Assembly instructions

Heraeus Noblelight

Safety instructions

Infrared emitters basically consist of pure quartz glass and a heating spiral.



There is a possibility that quartz glass of the emitters may either break or chip off. (Glass splinters in the emitter cannot always be clearly seen).

Users might hurt themselves on the broken emitter glass. Quartz glass splinters may drop on the materials to be exposed to radiation. In order to avoid damage to property or injuries to persons, the machine manufacturer/operator must take appropriate measures (as regards the design/maintenance intervals).



Infrared radiation is an intensive heat source!

Extreme heat radiation of this type may harm the human body as a result of the heat produced in the absorption process (comparable to danger from an open or blazing fire).

The most immediate risk is of IR erythema (skin burns). Additionally, medical studies have emphasised that the use of IR radiation, particularly when over-used for years or decades, can damage the cornea and the lens, causing an IR cataract.

To protect the machine operator from the heat produced by the IR emitters during the heating process, the DIN EN 12198 Directive "Machine Safety: Evaluation and Risk Reduction from Radiation-emitting Machines" was established, which serves as the basis for categorising the IR radiation emitted by machines and also lists the measuring procedures and safety and protection measures to be taken (e.g. housing of IR emitter, IR protective filter in accordance with DIN EN 171 as personal eye protection).

The machine directive should be taken into account by the machine manufacturer when designing machines using IR light as a heat source.

The Infrared Heating System may only be used by skilled and specifically-instructed operating personnel. The system operator/owner must provide a procedure-specific operating manual with instructions for the operating personnel.



If a potentially explosive atmosphere can be formed (resulting from solvent vapour/air mixtures), the relevant standard EN 1539 must be observed

sincere there is a risk of ignition at the infrared twin-tube emitter (the solvent vapour concentration must be below 25% of the lower explosion threshold).

Released vapours must be expelled at the installation site by the customer. The safety regulations for coating material processes (Germany: BGV D 25) must be observed.

The IR Heating System may be used only for industrial heating and drying processes (General safety regulations in accordance with EN 60519-1/DIN VDE 0721, Part 911).

The safety and function of the IR Heating System are guaranteed only if original parts and replacement parts from HERAEUS Noblelight are used.



Disregard of the safety regulations or improper operation of the Infrared Heating System can lead to injuries and material damage.

Assembly

To install our IR emitters, usually one clamp mounting and on spring mounting, and, if necessary, one or several central supports all manufactured by HNG are to be used.

The Carbon IR emitter must be secured in position of a stable support (steel support plate: ≥ 1.5 mm).

The Carbon IR emitter can be run in any installation position.

i **If the emitter is to be fitted in a vertical installation position, ensure that the tension spring on the carbon strip (integrated in the emitter) is fitted in the lower section and the emitter is fastened with the special mounting plates (with angle).**

The Carbon IR emitter(s) must be assembled in the following order:

- Drill mounting holes with $\varnothing 9.2$ mm for clamp spring in the support (mounting plate) at distance L.
- Screw the clamp spring in place with ceramic washers (1) on the mounting plate (4).
- Press the carbon IR emitter into position in the retaining spring clip. The carbon strip of the emitter must point at all the surface to be heated. The gold reflector should be pointing towards the support plate.
- Tighten the fastening nuts (2) on the knurled nut (3).
- Pulling the connection cable must not cause any tension on the flat base.
Bending radius of connection cable: > 30 mm

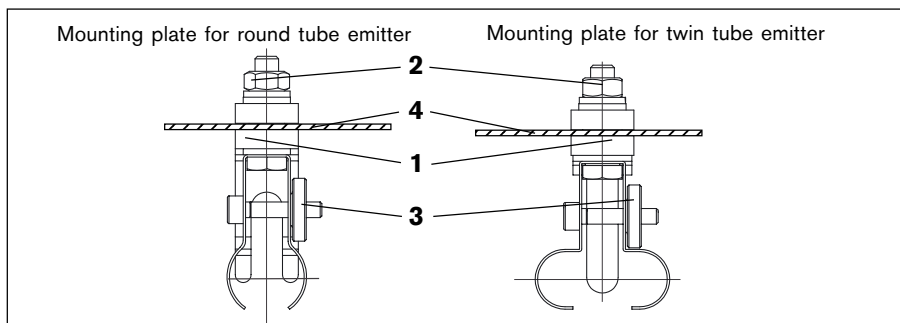

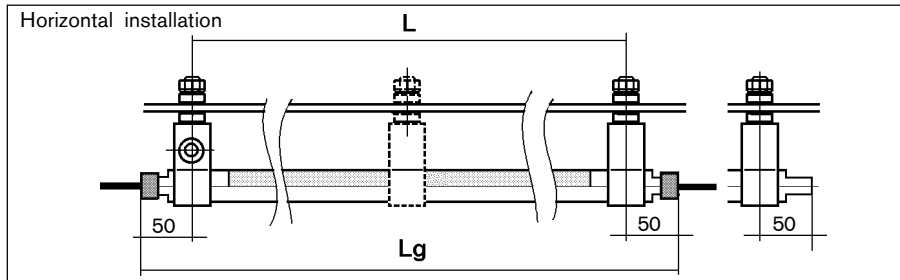

Mounting dimensions: $L = \text{Overall length of emitter } L_G - 2 \times 50 \text{ mm}$

i At the overall emitter lengths $L_G > 2000 \text{ mm}$ a central support (second clamp spring) is necessary.

After installation, the quartz glass tube of the IR emitter must be cleaned on the side without gold plating. For this purpose, please use the cleaning cloth included in our delivery or a clean linen cloth (without textile finishing agents) soaked in methylated spirit to remove any impurities/soiling or fingerprints from the surface.

i **The gold-plated side must not be cleaned.**

Electrical connection and maintenance

The electrical connection of the Carbon IR emitter must be carried out by authorised skilled personnel in compliance with the relevant safety regulations (in Germany, for example, the electrical engineering standard DIN VDE 0100 and the safety regulations UVV BGV A 2 "Electrical Systems and Operating Equipment").

Lead the cable ends of the Carbon IR emitter to the junction box without bunching them and cut them to the required length if possible.

Fit a cable sleeve to the bare connection end of the cable.

Following the electrical connection, the Carbon IR emitter must be checked according to DIN EN 60519-2/VDE Teil 411 "Industrial Electrical Heating Systems" (equipment and accessories).

Due to its design, the Carbon IR emitter has a certain output tolerance range.

This is why after the installation of one or several emitters into a system, its/their overall power consumption must be checked to ensure compliance with the specifications.

Maintenance

The Carbon IR emitter is maintenance-free. We recommend, however, that you check the function and cleanliness of the IR emitter regularly (especially the quartz glass). Soiled quartz glass should be cleaned. Proper function of the emitter is only ensured if the quartz glass remains clean.

Defective Carbon IR emitters should be replaced.

If you have any queries, contact Heraeus Noblelight.

Accessories

Designation	Part number	Tubing format in mm	Dimensions in mm				Fixing bolt
			a	b	c	d	
Clamp mounting Spring mounting	4510 6266 4510 6267	Ø 19	19 (25)	19	37,2	44,7	M6
Clamp mounting Spring mounting Central support	0975 8026 0975 8018 0975 8018	34x14	34	15	37,2	44,7	M6
The following holders must be used for vertical installation of the twin-tube emitters:							
Clamp mounting Spring mounting	8001 2071 8001 2072	Ø 19	19 (25)	19	37,2	44,7	M6
Clamp mounting Spring mounting	8001 2079 8001 2080	34x14	34	15	37,2	44,7	M6

